

4 3 2 1

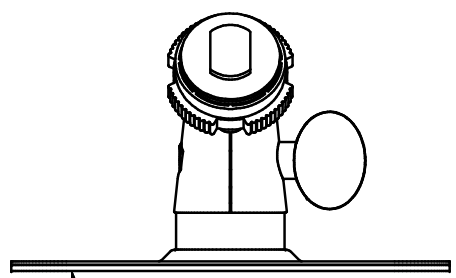
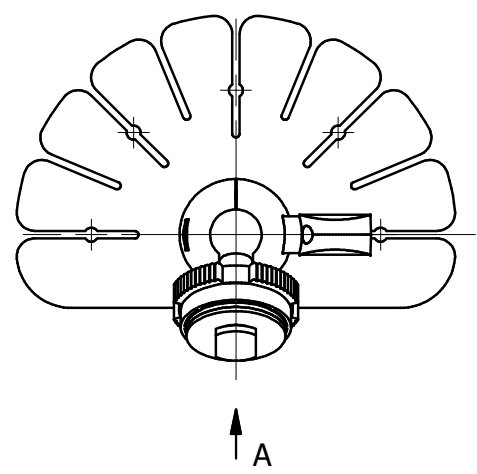
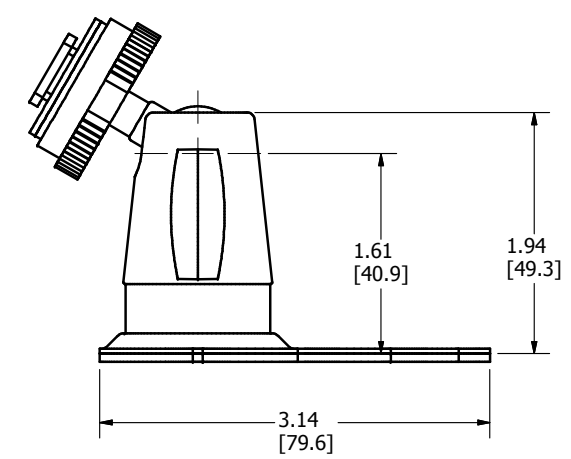
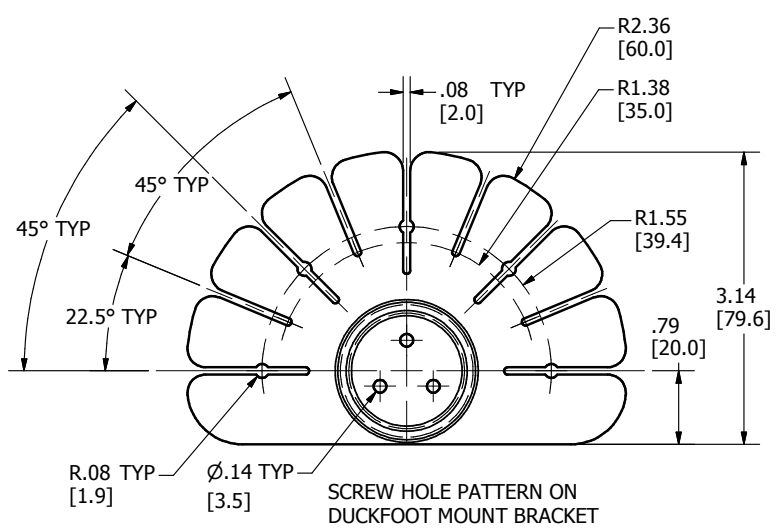

VIEW A-A
SCALE 3/4

ADHESIVE PAD

4 3 2 1

DRAWN	ku	5/23/2012
CHECKED		
QA		
MFG		
APPROVED		
ANGULAR TOLERANCES .15°		
TOLERANCES .XX ±		
0 - 5.99°	0.02	0 - 5.999° 0.010
6.00° - 11.99°	0.05	6.000° - 11.999° 0.015
12.00° - 23.99°	0.08	12.000° - 23.999° 0.020
24.00° - 47.99°	0.12	24.000° - 47.999° 0.025
48.00° & UP	0.12	48.000° & UP 0.030

ROSCO, INC		90-21 144TH PL. JAMAICA NY 11435 (718)526-2601	
		TITLE UNIVERSAL LCD MONITOR DUCKFOOT	
SIZE B	DWG NO STSDF1002	REV 4	
SCALE	SHEET 1 OF 1		