

VisionSystems

Safe-T-Scope™ 5" Rearview Backup Camera System

INSTALLATION/USER'S MANUAL
STSK5465



90-21 144th Place
Jamaica, NY 11435

1.800.227.2095
www.roscovision.com

● **WARNING**

1. To prevent electrical shock, **DO NOT OPEN THE MONITOR CASE.**
There are dangerous voltages inside the monitor. There are no user serviceable parts inside.
2. Avoid exposing monitor to water, rain, moisture etc. It is NOT waterproof. Any moisture inside the monitor could cause extensive damage.
3. Do not disassemble the camera. This voids the warranty.
Disassembling the camera will compromise the waterproof seal.

● **STORAGE**

1. Do not expose the monitor to excessive heat or cold. Storage temperature $-15^{\circ}\sim+170^{\circ}$ F, and operating temperature is $-5^{\circ}\sim+150^{\circ}$ F.
2. Do not store or operate in humid environments.

● **GENERAL**

1. This system is intended for use in automotive applications. Power source should be an automobile storage battery (12V/24V).
2. Make sure all cables are connected properly. Improper cable connections may damage the monitor. Remove the cable connection when you do not intend to use the unit for a long period of time
3. Please install this system according to the instructions in this manual.
4. Connect the system to an ignition switched power source. Connection to an unswitched battery source will reduce battery life.



This device complies with Part 15 of the FCC Rules. Operation is subject to the following two conditions:

- (1) This device may not cause harmful interference.
- (2) This device must accept any interference received, including interference that may cause undesired operation.



 **Warning!**

1. High voltages exist within the monitor. Opening of monitor case is unsafe, and never necessary for operating purposes.
2. In case of any failure, please turn off the display at once, and notify our company or the corresponding dealer. The monitor and camera are made up of many precise electronic components. Any disassembly or modification may lead to damage and voiding of warranty.

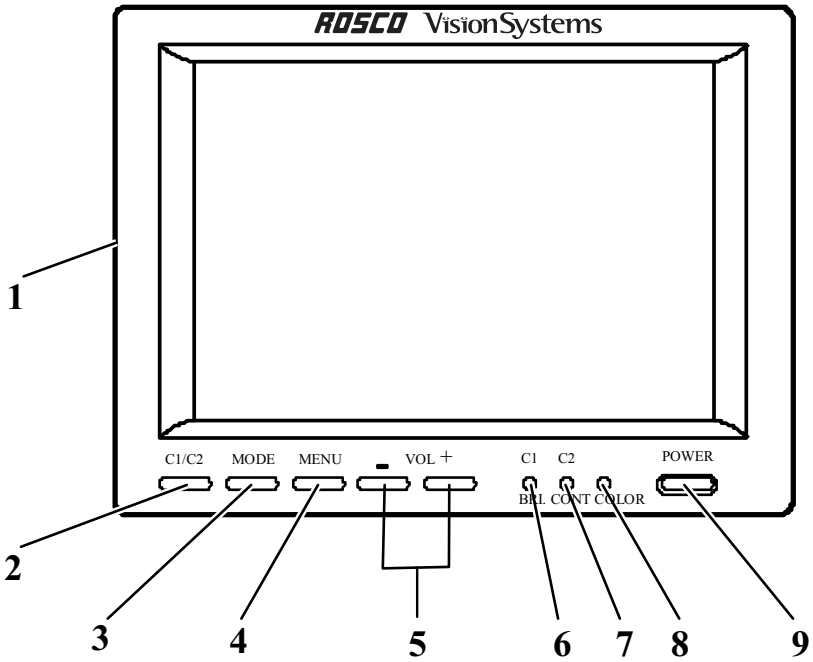

Front view

1. Mini Switches - Turns mirror function on and off for Camera 1 and Camera 2
2. C1/C2 - Switches from camera 1 to camera 2 and vice versa
3. Mode - Day/Night Dimming & Menu Control
4. Menu - Switches to setup mode (See p.8 for options)
5. Volume +/- & Menu Control - Increases & Decreases Volume & Adjust Menu settings
6. Cam 1 - Indicator & Brightness Control
7. Cam 2 - Indicator & Contrast Control
8. Color - Indicates dimming status & Tint Control - LED is lit orange if the monitor is operating in day mode
9. Power Switch - Switches Monitor from Stand-by to Steady-on

COLOR BACKUP CAMERA SYSTEM

STSK5465

INTRODUCTION

Please read this manual thoroughly. This manual contains instructions to make the installation of the camera and monitor easier. The color backup camera system is a supplement to standard rear-view mirror systems, and will provide additional rear-view vision when installed and maintained properly. It is not intended in any way to be a substitute for careful and cautious driving. All applicable traffic laws and motor vehicle safety regulations must still be obeyed.

FEATURES

STSC141 CAMERA

- 270,000 pixel image sensor
- 0.1 Lux sensitivity (18 IR-LED)
- Field of view 120° Diagonal
- Back Light Compensation (BLC)
- Automatic electronic iris provides a clearer, more consistent image in low and bright light
- Compact and lightweight design installs easily into most vehicles
- Waterproof/dustproof IP67 rating
- Wind deflector reduces buildup of dirt on lens

STSM241 TFT LCD COLOR 5" MONITOR

- Menu Control for Picture, System and Options
- Camera 1/Camera 2
- Power/stand-by switch
- Powerful built-in speaker

Expansion Capability - System can Accept up to 2 Camera Inputs

CONTENTS OF COMPLETE SYSTEM

1 Camera

- with Accessories - Mounting Bracket w/ hardware
- Wind Deflector
 - 65' Camera extension cable

1 Monitor

- with Accessories - Sunshield
- "Duckfoot" universal bracket for surface-mounting of monitor on dashboard or headliner, including adhesive pad
 - Power / Video / Audio Distribution harness for up to 2 Cameras

INSTALLATION INSTRUCTIONS

IMPORTANT: For typical rear-view installation, the rear camera MUST be connected to the distribution harness at the connector marked “REVERSE”

Note: The following instructions are for typical rear-view application.

STSC141 CAMERA

1. Attach camera bracket close to rear marker lights, centered on vehicle (see Fig. 1). Attachment point must be sturdy enough to support camera and bracket.
2. We do not recommend mounting the camera near the lower area of the vehicle (ex: bumper). This reduces the view of the camera and increases the chance of physical damage to the camera.
3. Before installing bracket to designated area, place gasket on the back of the bracket.
4. Place screw grommet on both top and bottom positions, then tighten screw to hold in place.
5. Fig. 4 (p. 13) shows how the bracket, gasket, grommet & screws should be installed.
6. Apply to vehicle and tighten to secure bracket into place.
7. Attach camera to bracket using screws provided. Adjust angle as indicated in Fig. 2. (Use rear bumper and back of vehicle as a reference point.)
8. Wind deflector may be installed. This deflector is designed to reduce the buildup of dust, dirt and moisture on the camera lens. (See Fig.3)

STSM241 MONITOR

1. Attach monitor inside vehicle in a location convenient to the driver (ex: center of dash, overhead, or flush-mounted in dash).
2. Attach the “duckfoot” bracket to the dashboard or to the headliner using self-tapping screws and/or adhesive pad.
3. Fasten monitor to “duckfoot” and adjust mounting angle to allow optimum driver viewing comfort. (See Fig. 6.)

STSH341 CAMERA EXTENSION CABLE

1. The camera to cable connection is waterproof. Be sure to position the cable properly. The male end attaches to the camera. The female end attaches to the power/video/audio distribution harness, typically located under the dashboard. (See Fig. 7.)

IMPORTANT: For typical rear-view installation, the rear camera MUST be connected to the distribution harness at the connector marked “REVERSE”

2. Do not run the cable over sharp edges or corners. Do not kink the extension cable. Keep the cable away from hot and rotating parts.
3. Stretch and tightly wrap tape around section where connectors meet. Cut excess tape if any. Place hand over taped area and squeeze tightly. This will ensure a tight fit. Over time tape will tighten more. (See Fig. 5.)
4. Fasten all cable runs, and secure all excess cable.

WIRING CAMERA AND MONITOR

Monitor:

1. Connect the red wire to an ignition switched accessory (ex: radio) power source, and connect the black wire to chassis ground. See wiring diagram for connections (See Fig. 7.)
2. Monitor: The monitor terminates in a 13-pin connector, which should be connected to the mating 13-pin receptacle end of the power/video/audio distribution harness.
3. For typical rear-view installation, connect the camera extension cable from the rear-view camera to the harness's connector marked REVERSE.
4. For multi-camera installations, be sure to mark each extension cable properly and connect to the appropriate harness connector marked CA1 or CA2. Bundle excess cable together using a cable tie or electrical tape.
5. The green wire is the REVERSE trigger wire. In typical rear-view installations, connecting this wire to the vehicle's backup light circuit will activate the rear-view image whenever the vehicle shifts into reverse.
6. Camera: Drill a 20mm (0.8in) diameter hole into vehicle body near the camera and bracket. Insert camera cable into vehicle (be careful not to kink cable) and fit grommet into hole. Apply sealant around grommet to increase resistance to water penetration. Connect camera to the camera extension cable which runs inside the vehicle.
7. Feed as much cable as possible into vehicle and clamp securely. This reduces the possibility of it being hooked or snagged.
8. Keep all cables away from HOT, ROTATING and ELECTRICALLY NOISY components.
9. **FUEL TANKERS & OTHER SPECIALTY VEHICLES:** All electrical equipment fitted to petroleum vehicles must be connected via battery master switch and must be isolated from the battery while the vehicle are loading and unloading. For other specialty vehicles, please check applicable code and regulations prior to installation.
10. Always consult your dealer when fitting any electrical or electronic equipment to a vehicle fitted with a CAN-bus or multiplex system.

IMPORTANT : For installations requiring multiple cameras, or for installations not requiring typical rear-view images, please refer to the wiring diagram (Fig.7) and the particular vehicle's electrical schematic for selection of proper power and trigger connection points.

FUNCTIONS AND OPERATION

MONITOR

1. MINI SWITCHES
Both mini switches activate the mirror function for Camera 1 or Camera 2
2. POWER
When the ignition is switched on, the monitor will be in standby mode (no image will be on the screen), waiting for trigger signal.
When a trigger wire is energized by 12v power (such as backup lights turning on), the image captured by the selected camera will appear on the monitor.
3. Pressing the power switch will change the monitor status from standby to steady-on. Steady-on mode status will show rear cameras view.
4. VOLUME +/-
Adjust Speaker Volume
These buttons are also used to adjust the values within selected setting of menu option
5. 'MENU' Button (See p.8)
Press the MENU button **once** to set desired **brightness**.
Press the MENU button **twice** to set desired **contrast**.
Press the MENU button **three times** to set desired **tint**.
6. MODE
Switching the monitor to day or night mode.
Press MODE
The monitor is switched from day mode to night mode or vice-versa.
The LED "COLOR" will be orange if the monitor is operating in day mode.
The LED "COLOR" will be green if the monitor is operating in night mode.
7. C1/C2
Switches from Camera 1 to Camera 2 and vice-versa

HOW TO SET YOUR MONITOR TO YOUR REQUIREMENTS

NOTE: On-screen menu commands may only be selected when monitor is in Steady-on (green light) mode. When monitor is in standby mode, and activated by trigger signal, on-screen menu commands are disabled.

Press the MENU button **once** to set desired **brightness**.

Press and hold “-” to **reduce** the brightness.

Press and hold “+” to **increase** the brightness.

Press the MODE button to exit setup mode.

Press the MENU button **twice** to set desired **contrast**.

Press and hold “-” to **reduce** the contrast.

Press and hold “+” to **increase** the contrast.

Press the MODE button to exit setup mode.

Press the MENU button **three times** to set desired **tint**.

Press and hold “-” to **reduce** the tint.

Press and hold “+” to **increase** the tint.

Press the MODE button to exit setup mode.

NOTE: You can reset the monitor to the factory settings for brightness, contrast, tint and volume.

To do this, proceed as follows

Press the MENU button once.

The LED C1 starts flashing.

Press the C1/C2 button.

Factory settings are set.

SPECIFICATIONS

STSC141 CAMERA

PICK-UP DEVICE	INTERLINE TRANSFER TYPE CCD
TV SYSTEM	PAL/NTSC
PICTURE ELEMENTS	512(H) x 582(V) PAL 512(H) x 492(V) NTSC
SENSING AREA	0.2x0.1in (4.9mm x 3.7mm)
IMAGE SIZE	1/4 inch
SYNCHRONIZATION	INTERNAL
HORIZONTAL RESOLUTION	420 TV LINES
REQUIRED ILLUMINATION	0 LUX MINIMUM/F1.2
SIGNAL TO NOISE RATIO	MINIMUM 48dB(AT AGC OFF)
POWER SUPPLY	12Vdc
POWER CONSUMPTION	3.5W(AT 12Vdc)
CURRENT CONSUMPTION	MAX. 200mA
LENS ANGLE	120°(D), 88°(H),66°(V)
OPERATION TEMPERATURE	-22°F to +149°F
STORAGE TEMPERATURE	-20°F to +176°F
WEIGHT	0.6Kg (0.41lb)
DIMENSIONS (W x H x D)	3 x 2 x 2in (75 x 48 x 49mm)

STSM241 MONITOR

SCREEN 5.0 inch (127mm)	COLOR TFT-LCD
DEFLECTION ANGLE	50°(LEFT/RIGHT), 15°(TOP), 35°(DOWN)
POWER CONSUMPTION	8W/700mA MAXIMUM
POWER SOURCE	12-30Vdc
TV SYSTEM	PAL/NTSC
VIDEO INPUT/OUTPUT	COMPOSITE VIDEO SINGLE 1VP-P 75 OHM
RESOLUTION	960(H) x 234(V)
CONTRAST	350:1
BRIGHTNESS	400cd/m ²
VIEWING ANGLE (U x D x R/L)	15 x 30 x 50
OPERATING TEMPERATURE	-5°F to +149°F
STORAGE TEMPERATURE	-13°F to +176°F
WEIGHT	0.4Kg (0.80lb)
OUTER DIMENSIONS (W x H x D)	5.7 x 4.3 x 1in (144 x 110 x 25mm) (without flush mount)

DISCLAIMER

The use of the STSK5465 Vehicle CCTV system should not in any way be used as a substitute for careful and cautious driving. Always obey traffic laws and motor safety regulations must always be adhered to.

Specifications subject to change without any notice.

Fig. 1

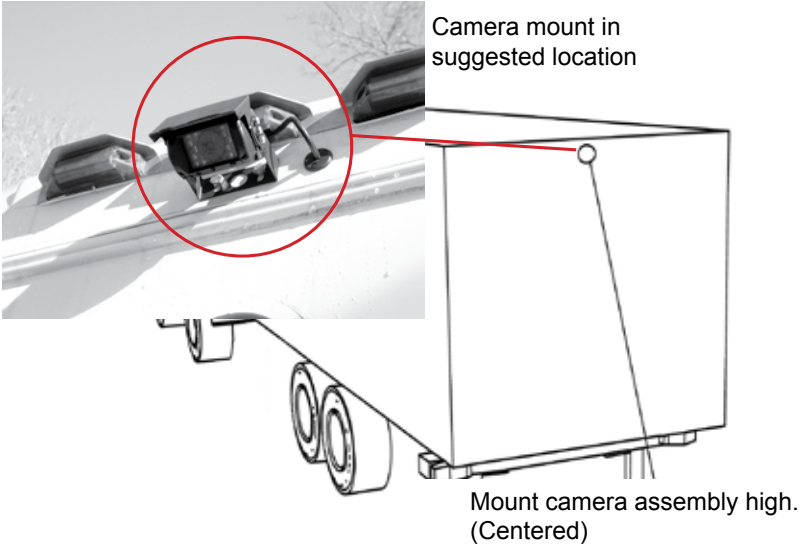

Camera mounting hole pattern

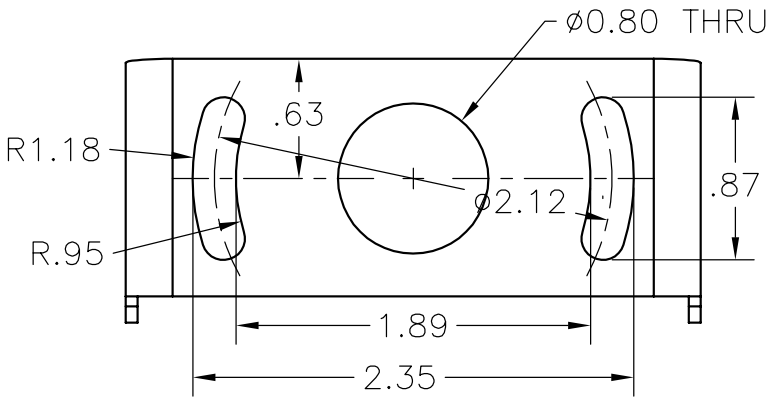
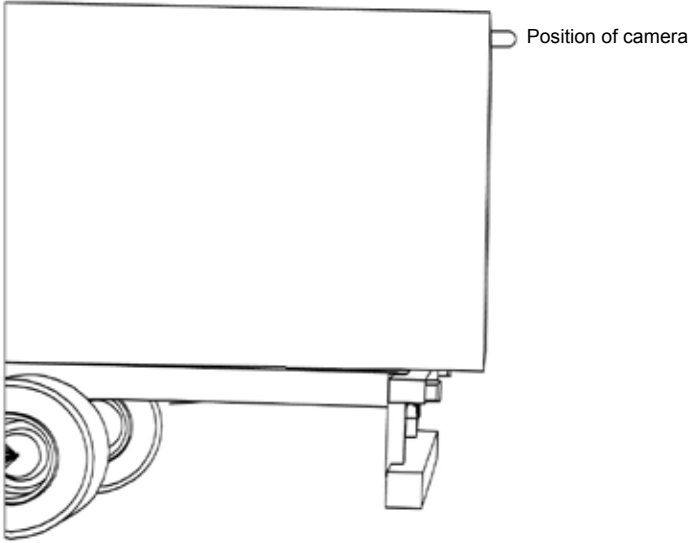

Fig. 2



Vehicles behind truck

Street



Rear Bumper

Typical monitor image of view from properly installed camera

Fig. 3

Optional wind deflector

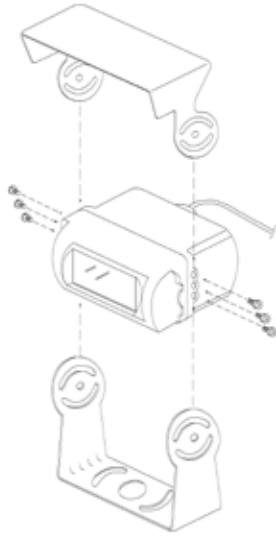

Fig. 4

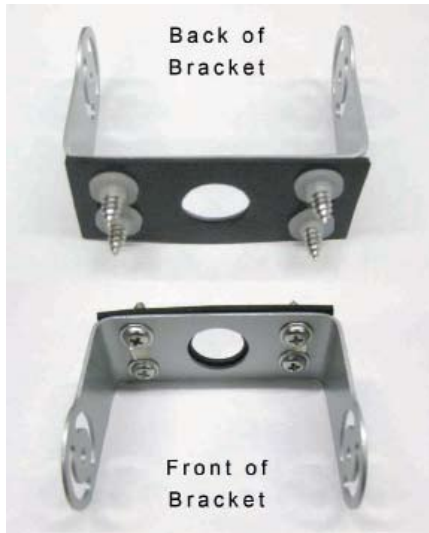
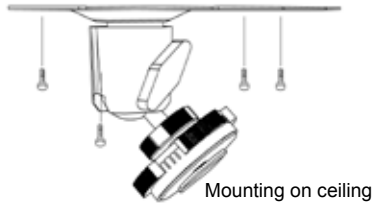

Fig. 6



Mounting on the dash, console etc.

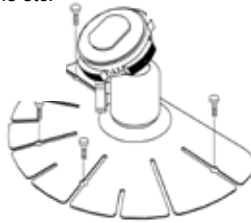
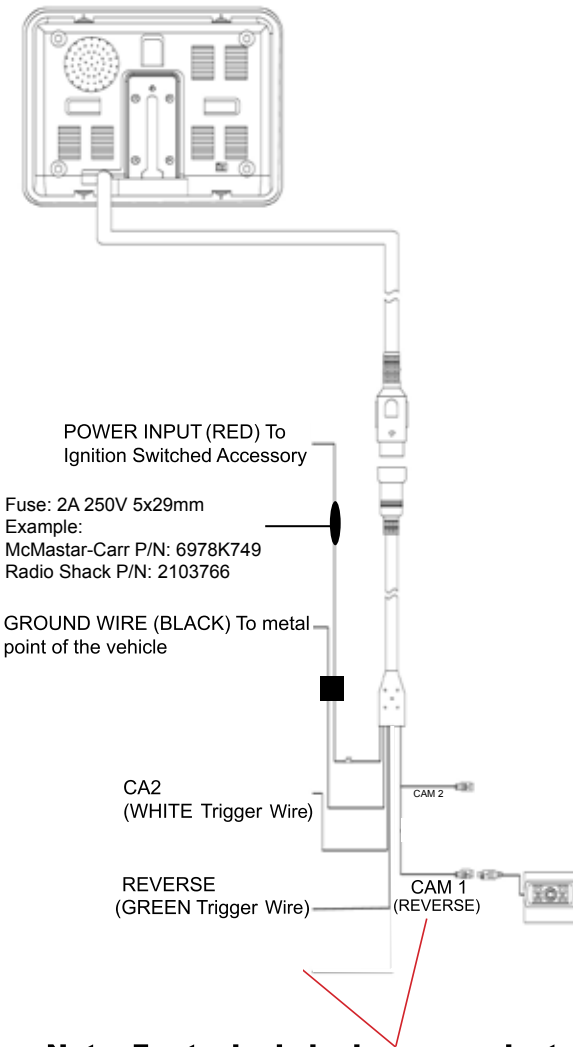

Fig. 5



Fig. 7



Note: For typical single camera installation, this trigger wire should be connected to the vehicle's "back up lights" circuit, and the rear-view camera should be attached to the connector marked "REVERSE"

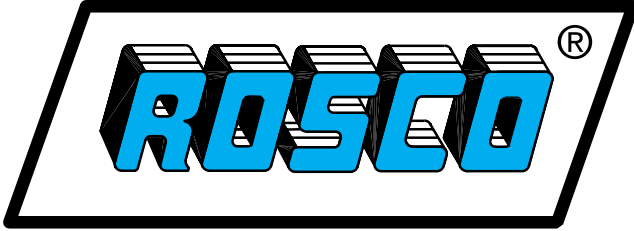

Vision Systems

90-21 144th Place
Jamaica, NY 11435

www.roscovision.com

Ph. 1.800.227.2095

Fx. 1.718.297.0323

**A Century of
Automotive Safety**



ISO 9001:2000 FM 78496
QS 9000:March 1998 FM 78495
Printed in China

Lit. P/N: 04242012