

#	DESCRIPTION	DATE	APPROVED
ECO#3957	A RELEASED TO PRODUCTION	01/28/2010	G.G.
ECO#5984	B UPDATED LIST OF INCLUDED ITEMS	6/26/2012	BF
ECO#6267	C DV212 was DV112	12/3/2012	G.G.
ECO#6297	D DV112 was DV212	1/7/2013	G.G.

DO NOT REMOVE SD CARD WHILE UNIT IS POWERED

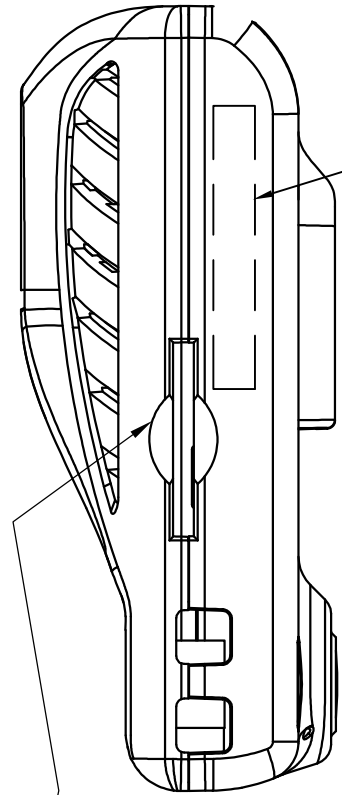
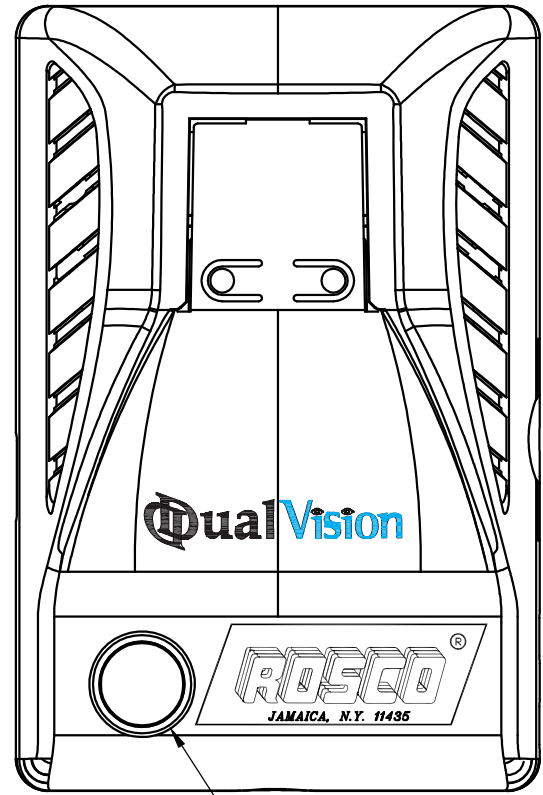
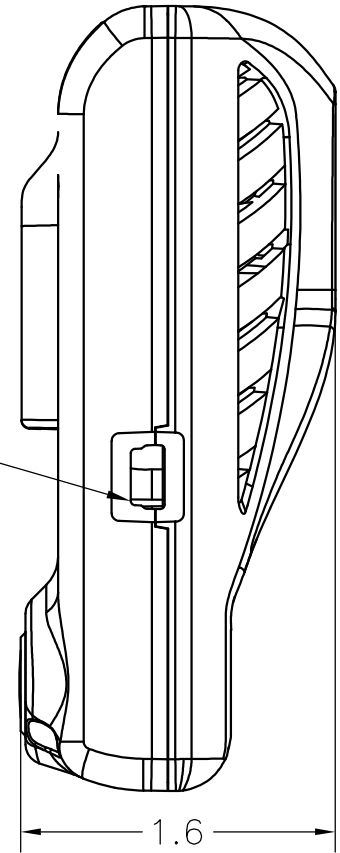
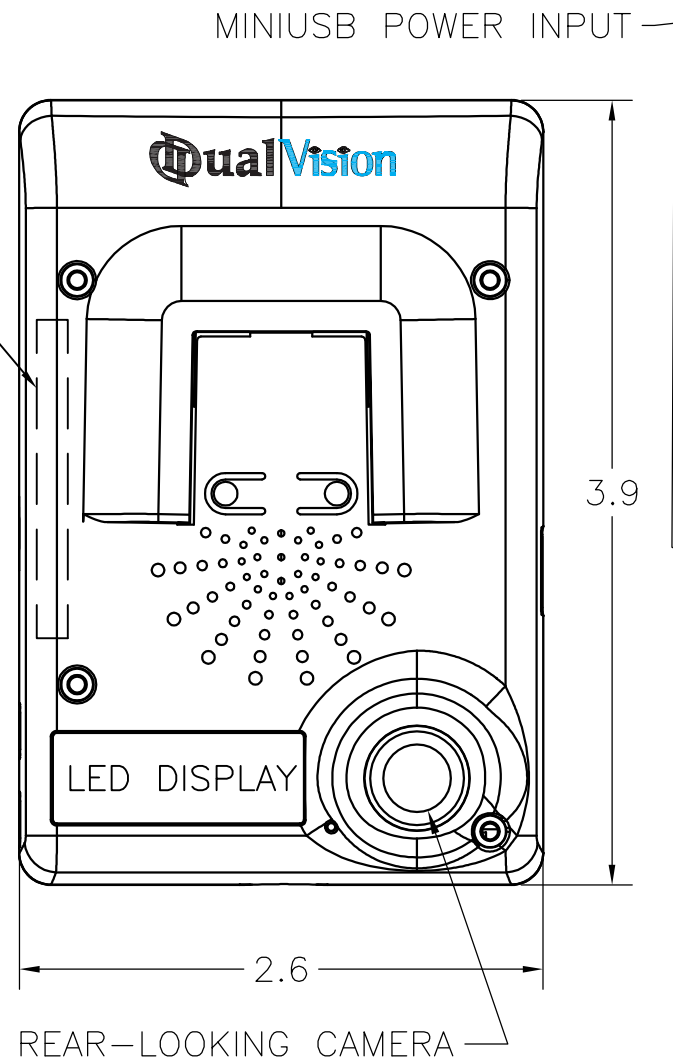

TO EXTRACT SD CARD USE COIN OR THIN EDGE TOOL

DV103  
DUAL-VISION RECORDER  
WITH ROSCO LOGO

- NOTES:  
 1 INCLUDED IN THIS PACKAGE;  
 DV103- DUAL-VISION RECORDER WITH ROSCO LOGO  
 DV136  
 DV137  
 DV135  
 BAS5033- CLEAR ACRYLIC MOUNT & ADHESIVE  
 LED1006- CLIP-ON IR MODULE  
 DV108- LBL1014, CD & QUICK START GUIDE  
 HAR6006- 12 VOLT POWER CORD, CIGARETTE LIGHTER  
 HAR6007- PANIC BUTTON  
 FUSE1003  
 DV110  
 DV112- 16 GB SDHC CARD

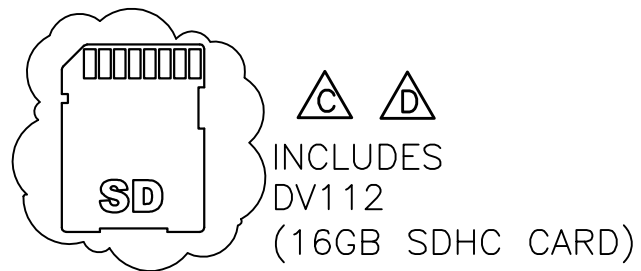

ALL DIMENSIONS IN INCHES	
TOL. .XXX ±.005; .XX ±.03 unless otherwise specified	
DRAWN 01/28/2010	
CHECK	J. SERER
APPR.	BEN ENGLANDER
ANGULAR TOLERANCES: ±0.5°	
THIS DRAWING AND/OR ITS RESPECTIVE CAD FILE IS THE PROPERTY OF ROSCO, INC. AND MAY NOT BE TRACED, COPIED OR OTHERWISE USED IN ANY MANNER WITHOUT THE WRITTEN AUTHORIZATION OF ROSCO INC.	

<b>ROSCO, INC</b>		144-31 91st AVE. JAMAICA NY 11435 TEL (718)526-260	
DUAL-VISION RECORDER W/ROSCO LOGO & ACCESSORIES; 16GB SDHC CARD			
SIZE	DRAWN BY	DWG NO	REV
B	G.G.	DV114	D
SCALE	WEIGHT	SHEET 1	