



# SAFE-T-SCOPE®

7" REARVIEW BACKUP CAMERA SYSTEMS



## STSK7165

INSTALLATION / USER MANUAL

**WARNING**

1. To prevent electrical shock, DO NOT OPEN THE MONITOR CASE.  
There are dangerous voltages inside the monitor. There are no user serviceable parts inside.
2. Avoid exposing monitor to water, rain, moisture etc. It is NOT waterproof.  
Any moisture inside the monitor could cause extensive damage.
3. Do not disassemble the camera or the monitor. This voids the warranty.  
Disassembling the camera will compromise the waterproof seal.

**STORAGE**

1. Do not expose the monitor to excessive heat or cold. The storage temperature of this machine is -22°F~+176°F, and operating temperature is -4°F~+158°F. The humidity is Rh 90%.
2. The monitor is not waterproof. Do not store or operate in moist or wet environments.

**MAINTENANCE**

1. Disconnect the cable connection to monitor before cleaning the unit.
2. Use a mild household detergent and clean the unit with a slightly damp cloth.

**GENERAL**

1. This system is intended for use in automotive applications. Power source should be an automobile storage battery (12V/24V).
2. Make sure all cables are connected properly. Improper cable connections may damage the system. Remove the cable connection when you do not intend to use the unit for a long period of time.
3. Please install this system according to the instructions in this manual.
4. Connect the system to an ignition switched power source. Connection to an unswitched battery source will reduce battery life.

**WARNING !**

1. High voltages exist within the monitor. Opening of monitor case is unsafe, and never necessary for operating purposes.
2. In case of any failure, please turn off the display at once, and notify our company or the corresponding dealer. The monitor is made up of many precise electronic components. Any disassembly or modification may lead to damage and voiding of warranty.



This device complies with part 15 of the FCC rules. Operation is subject to the following two conditions:  
(1) This device may not cause harmful interference.  
(2) This device must accept any interference received, including interference that may cause undesired operation.



## STSK7165 COLOR BACKUP CAMERA SYSTEM

### INTRODUCTION

Please read this manual thoroughly. This manual contains instructions to make the installation of the camera and monitor easier. The color backup camera system is a supplement to standard rearview mirror systems, and will provide additional rearview vision when installed and maintained properly. It is not intended in any way to be a substitute for careful and cautious driving. All applicable traffic laws and motor vehicle safety regulations must still be obeyed.

### FEATURES

#### STSC101 CAMERA

- 482,000 pixel image sensor
- 0 Lux sensitivity (4 IR-LEDs)
- Auto White Balance (AWB)
- Field of View (86° (H), 72° (V), 122° (D))
- Back Light Compensation (BLC)
- Automatic electronic iris provides a clearer, more consistent image in low and bright light
- Compact and lightweight design installs easily into most vehicles
- Waterproof/dustproof IP69K rating
- Wind deflector reduces buildup of dirt on lens

#### STSM205 TFT LCD COLOR 7" MONITOR

- Menu button for Picture, System and Options
- Camera 1/Camera 2 /Camera 3
- Power/stand-by switch
- Powerful built-in speaker

**Expansion Capability - System Can Accept Up To 3 Camera Inputs**

#### PARTS LIST

- 1 Camera
- 1 Camera bracket
- 4 Attachment screws with washers
- 1 Wind deflector
- 1 Monitor
- 1 Sunshield
- 1 "Duckfoot" universal bracket for surface-mounting of monitor on dashboard or headliner, including adhesive pad
- 1 U-Bracket - Optional mount
- 1 Adaptor for flush-mounting of monitor in dashboard
- 1 Power/video/audio distribution harness for up to 3 cameras
- 1 65' Camera extension cable

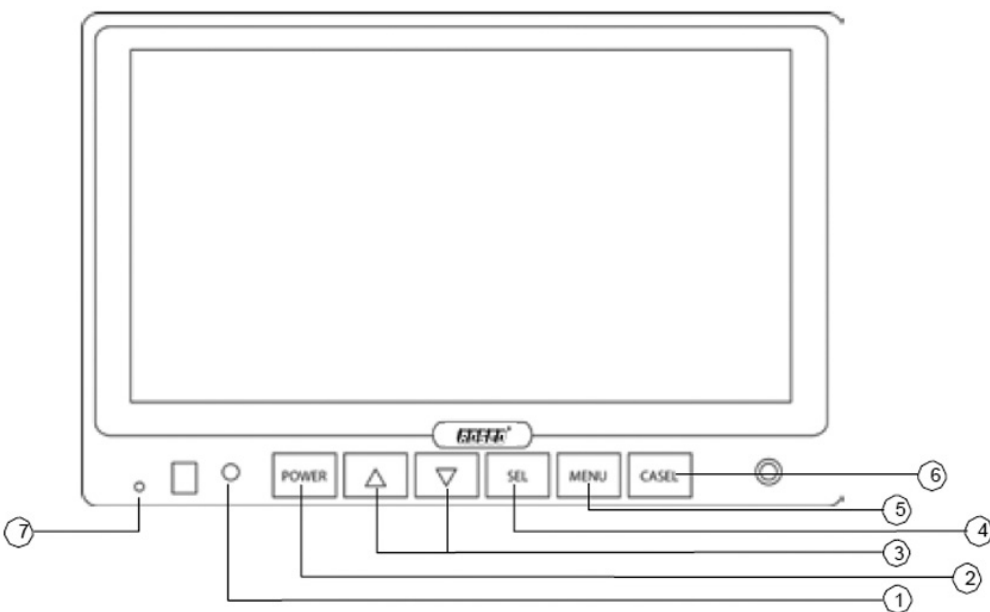

#### Front View

1. Power indicator
2. **Power**
3. up/down or less/more
4. SEL scle on/off or menu selection
5. **MENU**
6. **CA SEL** camera selection
7. Day/Night Sensor

## INSTALLATION INSTRUCTIONS

Note: The following instructions are for typical rearview application.

### STSC101 CAMERA

1. Attach camera bracket close to rear marker lights, centered on vehicle **(see Fig.1.)**  
Attachment point must be sturdy enough to support camera and bracket.
2. We do not recommend mounting the camera near the lower area of the vehicle (e.g. bumper). This reduces the view of the camera and increases the chance of physical damage to the camera.
3. Attach camera to bracket using screws provided. Adjust angle as indicated in **Fig. 2.** (Use rear bumper and back of vehicle as a reference point.)
4. Wind deflector may be installed. This deflector is designed to reduce the buildup of dust, dirt and moisture on the camera lens. **(See Fig.3)**

### STSM205 MONITOR

1. Attach monitor inside vehicle in a location convenient to the driver (e.g. center of dash, overhead, or flush-mounted in dash).
2. Attach "U" or "duckfoot" bracket to the dashboard or to the headliner using self-tapping screws and/or adhesive pad. **(See Fig. 4.)**
3. Fasten monitor to bracket and adjust mounting angle to allow optimum driver viewing comfort.

### CABLE

1. The camera to cable connection is waterproof. Be sure to position the cable properly. The male end attaches to the camera. The female end attaches to the power/video/audio distribution harness, typically located under the dashboard. **(See Fig. 5.)**

**IMPORTANT:** For typical rear-view installation, the rear camera **MUST** be connected to the distribution harness at the connector marked "CA3"

2. Do not run the cable over sharp edges or corners. Do not kink the cable. Keep the cable away from hot and rotating parts.
3. Fasten all cable runs, and secure all excess cable.

## WIRING CAMERA AND MONITOR

1. See wiring diagram for connections to ignition, ground and "backup lights" circuit. **(See Fig. 5.)**
2. Before drilling, be sure no cable or wire is on the other side. Be sure to drill a 20mm (0.8in) diameter hole only.
3. Feed as much cable as possible into vehicle and clamp securely. This reduces the possibility of it being hooked or snagged.
4. Keep all cables away from HOT, ROTATING and ELECTRICALLY NOISY components.
5. Camera: Drill a 20mm (0.75in) diameter hole into vehicle body near the camera and bracket. Insert camera cable into vehicle (be careful not to kink cable) and fit grommet into hole. Apply sealant around grommet to increase resistance to water penetration. Connect camera to the camera extension cable which runs inside the vehicle.
6. Monitor: The monitor terminates in a 13-pin male connector, which should be connected to the mating 13-pin receptacle end of the power/video/audio distribution harness.
7. For typical rear-view installation, connect the camera extension cable from the rear-view camera to the harness's connector marked CA3.
8. For multi-camera installations using cameras CA1 and/or CA2, be sure to mark each extension cable properly and connect to the appropriate harness connector marked CA1 or CA2. Bundle excess cable together using a cable tie or electrical tape.
9. Connect the red wire to an ignition power source, and connect the black wire to chassis ground. The brown wire is the trigger wire. In typical rear-view installations, connecting this wire to the vehicle's backup light circuit will activate the rear-view image whenever the vehicle shifts into reverse.
10. **FUEL TANKERS & OTHER SPECIALTY VEHICLES:** All electrical equipment fitted to petroleum vehicles must be connected via battery master switch and must be isolated from the battery while the vehicle are loading and unloading. For other specialty vehicles, please check applicable code and regulations prior to installation.
11. Always consult your dealer when fitting any electrical or electronic equipment to a vehicle fitted with a CAN-bus or multiplex system.

**IMPORTANT:** For installations requiring multiple cameras, or for installations not requiring typical rear-view images, please refer to the wiring diagram (Fig.5) and the particular vehicle's electrical schematic for selection of proper power and trigger connection points.

## FUNCTIONS AND OPERATIONS

### MONITOR

#### 1. POWER LED

When the red LED is on, it indicates power on, monitor in standby mode, waiting for trigger signal. When a trigger is selected, the image captured by the selected camera will appear on the monitor.

2. An on-screen scale will appear when the trigger (typically rear-view) for camera 3 is energized.

3. Pressing the power switch will change the monitor status from standby to steady-on. Steady-on mode status indicated by green LED light.

4. In steady-on mode, driver may activate the scale by pressing the SEL button. Pressing SEL again will remove the scale.

#### 5. ▲▼ CONTROL BUTTON

These control buttons are used to adjust the values within selected options

#### 6. SEL SELECT CONTROL BUTTON

Use the button in order to select the required option in the menus.

**\* NOTE: Prior to accessing menu options, place monitor into Steady-On (Green Light) mode.**

#### 7. 'MENU' Button

Each press of the 'MENU' will bring up one of the following screens.

- PICTURE
- OPTION
- SYSTEM

The menu list will disappear if no selection is chosen within 15 seconds.

#### 8. CA.SEL

Camera selector button

Enables selection of CA1, CA2 and CA3.

The OSD (On Screen Display) indicates which camera is currently operating.

#### 9. REMOTE-CONTROL SENSOR

The monitor can be operated via remote control. If using remote control, ensure that the IR on the remote control is facing the monitor.

## HOW TO SET YOUR MONITOR TO YOUR REQUIREMENTS

**NOTE:** On-screen menu commands may only be selected when monitor is in Steady-on (green light) mode. When monitor is in standby mode, and activated by trigger signal, on-screen menu commands are disabled.

### 1. PICTURE CONTROL

1.1 Press the MENU button once to enter picture menu

1.2 Move the cursor to the BRIGHT, CONTRAST, COLOR and

### VOLUME

1.3 Using SEL button, highlight the item you wish to change

1.4 Press the ▲▼ buttons to adjust values

1.5 Press the MENU button to close menus, or SEL button to adjust a different menu item.

### 2. OPTION CONTROL

2.1 Press the MENU button twice to enter OPTION

2.2 Press SEL to select language, scale, or camera settings

2.3 Press the ▲▼ button to adjust values/items within the selected field

2.4 Select one of two options to view NORMAL or MIRROR image settings

NOTE: changing the image will also change the OSD

### 3. SYSTEM CONTROL

3.1 Press the MENU button

3.2 Select SYSTEM

3.3 Move the cursor to the COLOR SYSTEM, BLUE BACK, HORIZONTAL, VERTICAL with the SEL button

3.4 Press the ▲▼ button to set value

## SPECIFICATIONS

### STSC101 CAMERA

PICK-UP DEVICE	1/3" Sharp CCD
TV SYSTEM	NTSC
PICTURE ELEMENTS	976(H) x 494(V)
SYNCHRONIZATION	INTERNAL
HORIZONTAL RESOLUTION	750 TV LINES
REQUIRED ILLUMINATION	0 LUX MINIMUM
POWER SUPPLY	12Vdc
POWER CONSUMPTION	≤ 3w @12 VDC
CURRENT CONSUMPTION	≤ 250 mA @ 12 VDC
FIELD OF VIEW	86°(H), 72°(V), 122° (D)
OPERATING TEMPERATURE	-22°F TO 158°F (-30°C TO +70°C)
STORAGE TEMPERATURE	-40°F TO 185°F (-40°C TO +85°C)
WEIGHT	0.69 lb (315g)
DIMENSIONS (W x H x D)	3.4 x 3.1 x 2.7in (80 x 80 x 70mm) (with mount)

### STSM205 MONITOR

SCREEN 7.0 inch (127mm)	HIGH QUALITY DIGITAL LCD
VIEWING ANGLE	50(T) x 70(B) x 70(L) x 70(R)
POWER CONSUMPTION	5W/12V
POWER SOURCE	10-32 Vdc
TV SYSTEM	PAL/NTSC
VIDEO INPUT/OUTPUT	COMPOSITE VIDEO SINGLE (1VP-P 75 OHM)
RESOLUTION	800 x 480
CONTRAST	500:1
BRIGHTNESS	400cd/m2
OPERATING TEMPERATURE	-4°F TO 158°F (-20°C TO +70°C)
STORAGE TEMPERATURE	-22°F TO 176°F (-30°C TO +80°C)
WEIGHT	445g
OUTER DIMENSIONS	7.2 x 4.8 x 1.2in (182 x 122 x 30mm)
(W x H x T) (without flush mount)	

Fig. 1

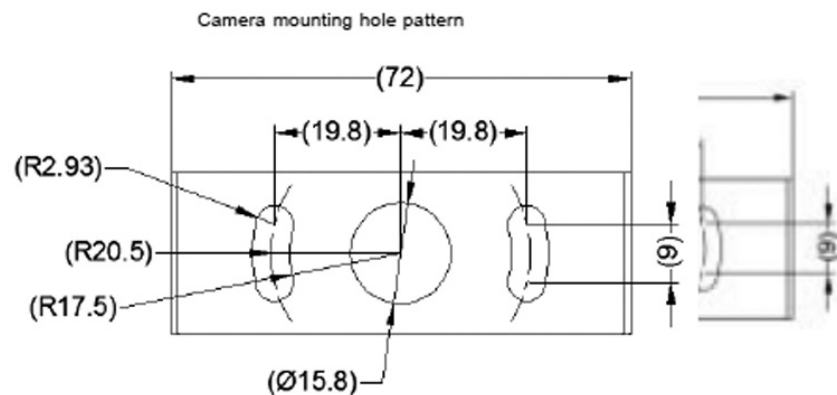
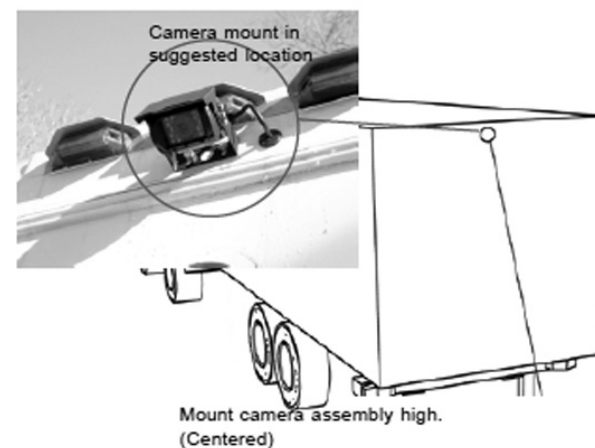

**DISCLAIMER:** The use of the STSK7165 Vehicle CCTV system should not in any way be used as a substitute for careful and cautious driving. Always obey traffic laws and motor safety regulations must always be adhered to. Specifications subject to change without notice.

Fig. 2

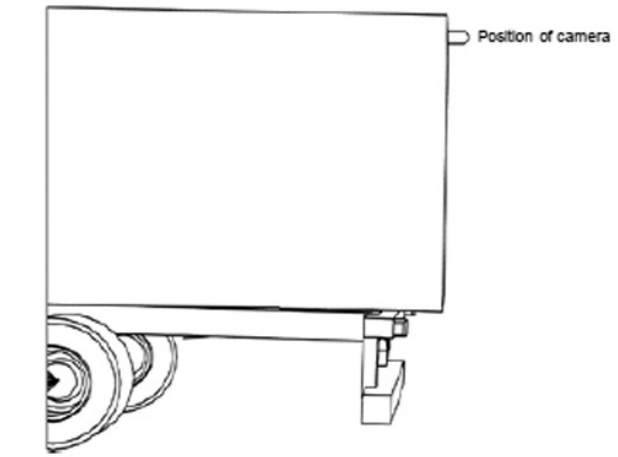

Vehicles behind truck

Street

Rear Bumper



Typical monitor image of view from properly installed camera

Fig. 3

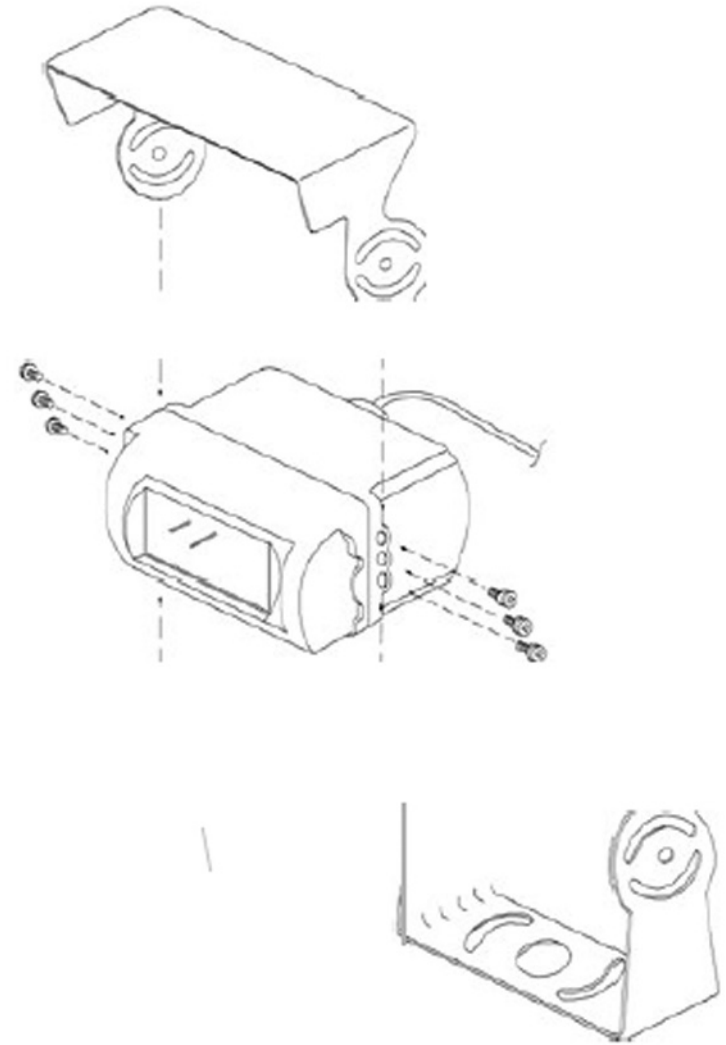
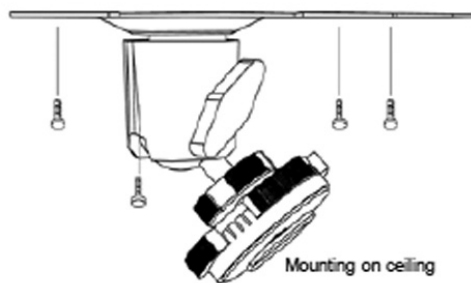

Fig. 4



Mounting on the dash, console etc.

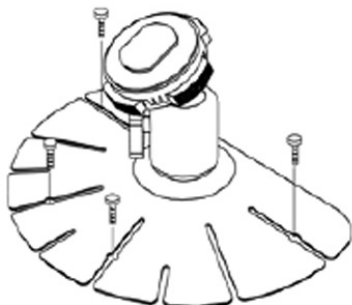
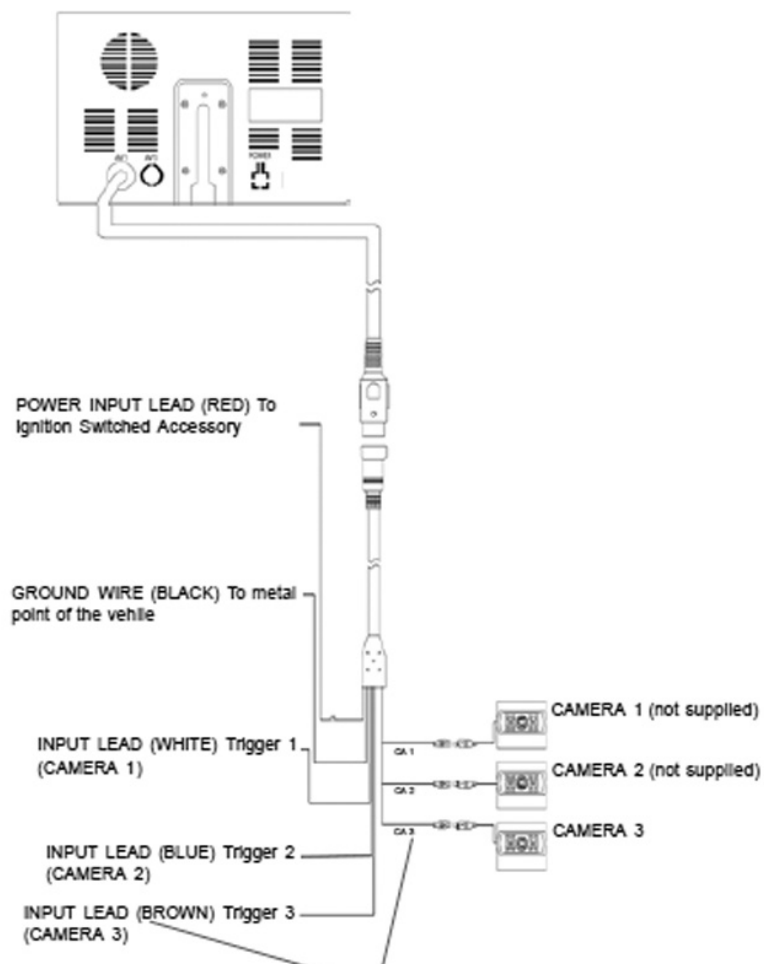

Fig. 5



**Note:** For typical single camera installation, this trigger wire should be connected to the vehicle's "back up lights" circuit, and the rear-view camera should be attached to the connector marked "CA3"





***A CENTURY OF AUTOMOTIVE VISION SAFETY***

90-21 144th Place, Jamaica, New York 11435

TEL (800) 227-2095 • FAX (718) 297-0323

[techsupport@roscovision.com](mailto:techsupport@roscovision.com) [www.roscovision.com](http://www.roscovision.com)

**RoHS FC**

Lit. P/N: M012617C

Lit. Rev Date: Jan 26, 2017